



Reference Inventory of Equipment for Silk Processing at the Cottage Level

Agricultural and Food Engineering Technologies Service (AGST)
Food and Agriculture Organization of the United Nations (FAO)





Table of Contents

Introduction

Chapter 1. Equipment for processing fresh cocoons to raw silk

- Stifling
 - Sun drying
 - Basket and barrel stifling
 - Steam oven
 - Electric
- Drying and storing
- Reeling
 - Cottage basin
 - Wood frame
- Hand stripping

Chapter 2. Equipment for processing raw silk to silk yarns

- Twisting, doubling, spinning and winding
 - Wood wheels
 - Equipment made from bicycle wheels
 - Charka
- Dyeing

Chapter 3. Equipment for processing silk yarns to silk cloths and final silk products

- Carpet weaving
 - Wooden carpet loom
 - Metal carpet loom
 - Carpet makers' hand tools
- Hand weaving
 - Backstrap loom
 - Simple treadle loom
- Knitting and Hand Stitching

Chapter 4. Commodities from cottage industry silk handcrafts

Chapter 5. Basic requirements for setting up silk cottage industries at the family and village levels

References

Introduction

The following reference inventory showcases equipment currently being used for cottage-level processing of silk. It is intended as a resource for anyone interested in promoting the development of raw silk handcraft cottage industries. The beneficiaries may be cocoon producers themselves who choose to reserve some or all of their production for home processing or people already involved in handcrafts who wish to make materials for their own use.

The equipment outlined in this document is focused on the processing of fresh cocoons into raw silk thread and yarn for use in crafts such as carpet making and hand weaving. It does not contain all of the necessary information for producing the standardised skeins known to international trade. Any subset of the tasks may be developed separately as desired or practical. Reeling and dyeing are good examples of stand-alone activities each with specialised equipment and techniques.

There are many different tools and variations of similar tools used around the world in the silk industries. This inventory will hopefully grow with additions and suggestions from interested parties. A number of the pieces of equipment currently included were measured and photographed in use in Turkey where there exists a small but active cottage industry. Visits to workshops were kindly arranged by Ayhan Karagozoglou and the staff of the Kozabilik Association in Bursa.

Equipment for Stifling Fresh Cocoons

Sun drying

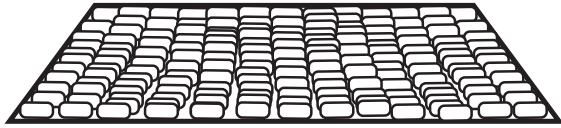

Sun drying requires the least infrastructure and the smallest input of energy. Fresh cocoons are spread evenly in a thin layer on a cloth in bright sun to kill the pupae and drive out moisture. This takes at least two to three days of good sunshine. UV light harms the strength and colour of the silk fibre. The cocoons must be taken in at night and protected from pests such as birds and mice. This may not be practical except for relatively small quantities.

Basket stifling

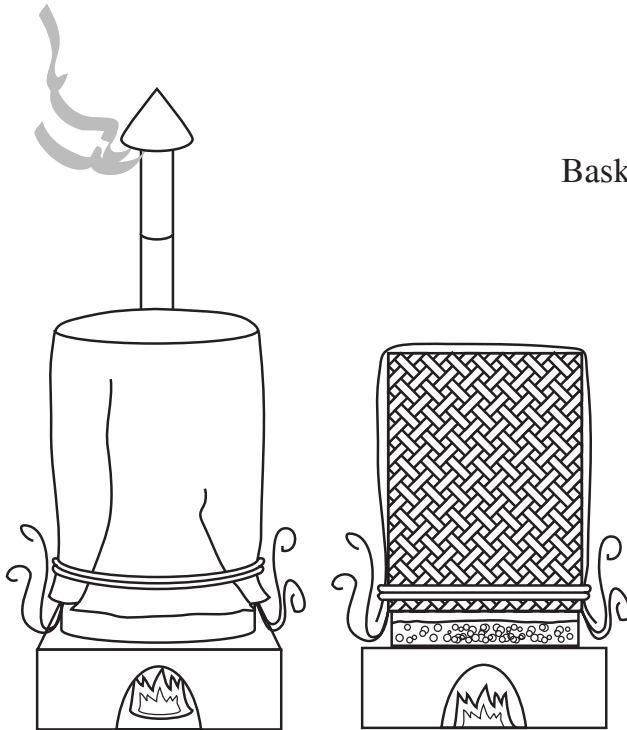

This method uses a heavy cloth to hold steam produced by a wood or gas fire in a loosely woven basket filled with fresh cocoons. The basket is placed over a shallow basin which holds the water. The pupae are killed within thirty minutes. The stifled cocoons are then spread to dry before storage.

Barrel stifling

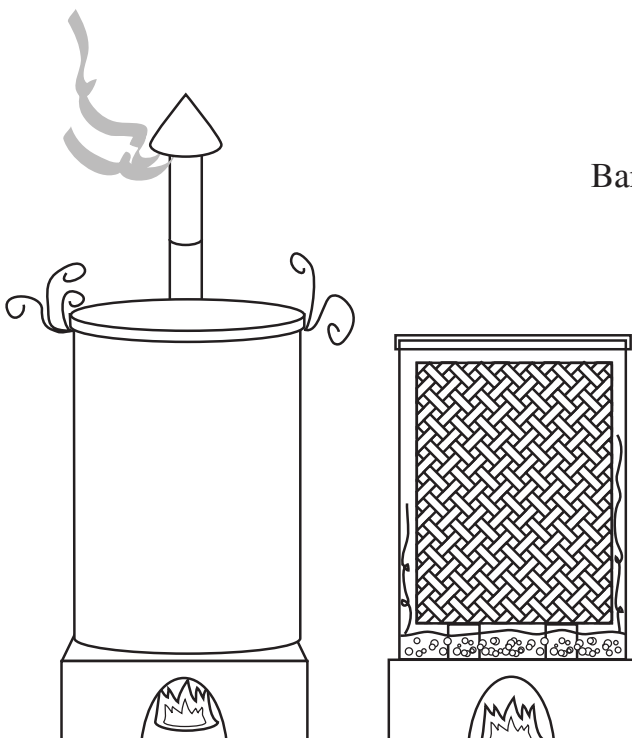

This method is similar to basket stifling. A basket filled with fresh cocoons is placed in a metal barrel to hold the steam. The basket must sit on blocks above the water level to avoid staining the cocoons. The pupae are also killed within thirty minutes. This method is somewhat more efficient in terms of fuel use than basket stifling because of the better containment of the steam.

Equipment for Stifling Fresh Cocoons

Steam Stifling Oven for village level production

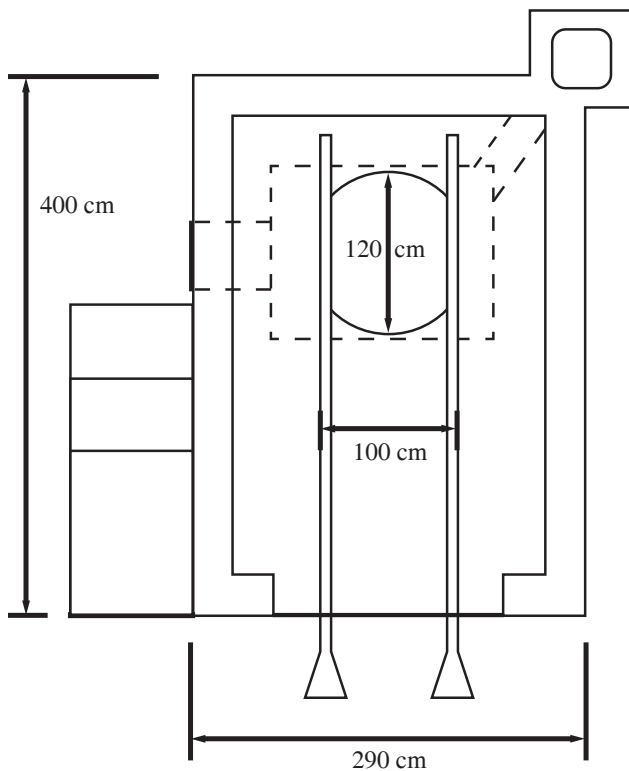
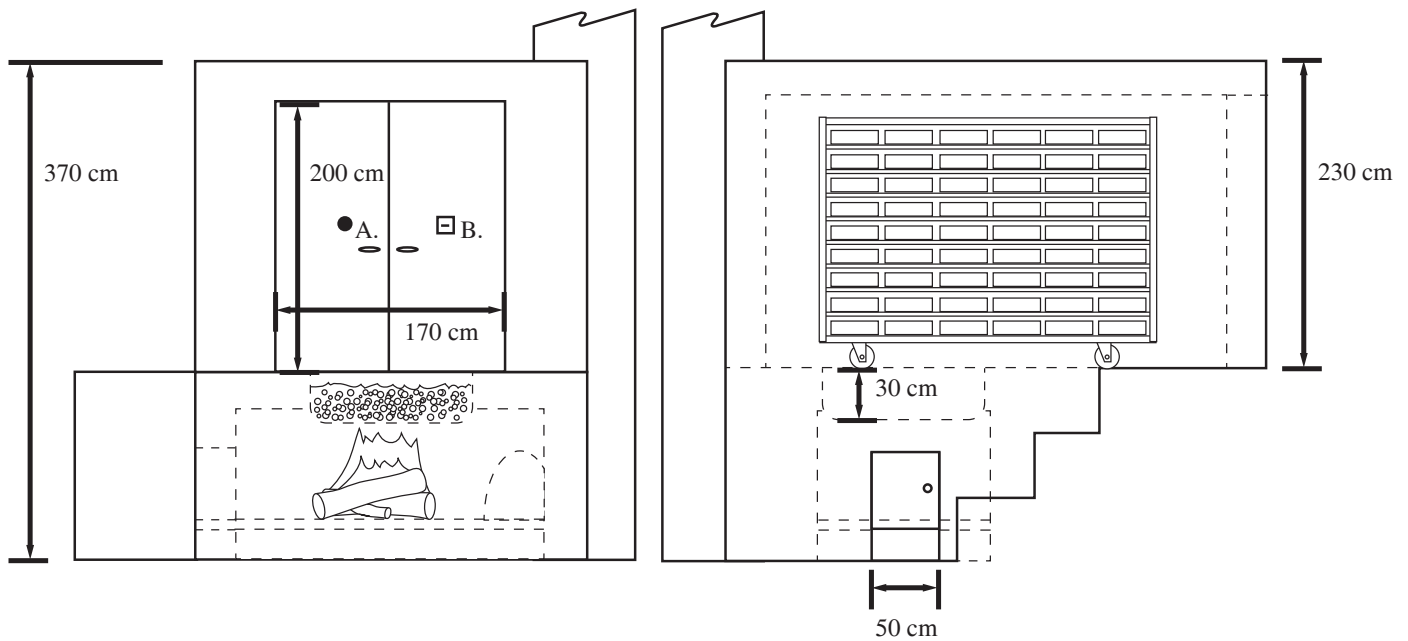

This steam stifling oven is made using standard masonry construction. It can stifl approximately 300 kg of fresh cocoons every 30 minutes with an operation temperature between 75 and 80 Degrees Celcius.

The doors are welded steel and must seal tightly to prevent the steam from escaping. A large copper basin is set in the floor with its bottom exposed to the fire box below. The oven, as shown, is fired with wood, but a burner can be installed to use oil or natural gas. A copper or steel water pipe runs to the basin and has an on/off valve outside allowing the basin to be refilled during the stifling process if necessary. The cocoons are placed on trays which are loaded on a special cart. Tracks made of 8 cm channel iron are set in the floor to guide the wheels of the cart over the basin.

A thermometer (marked A. on the drawing) and a small, wooden test box (marked B.) are set in the main doors. A handful of fresh cocoons is placed in the box each time the oven is loaded. After about twenty

five minutes of steaming, a cocoon from the test box is cut open and the pupa is checked. A thoroughly stifled pupa is cooked through to the center.

The owners of this oven said they needed about one quarter as much wood as the weight of fresh cocoons to be stifled as an average over the whole season. That is on average 75 kg wood for every 300 kg fresh cocoons. The entire design could likely be scaled down to accomodate smaller volume requirements

Equipment for Stifling Fresh Cocoons

This is a view of the interior of the oven. It shows the basin, the tracks for the cart's wheels and one of the steel doors which is seen open on the left side of the photo. A foam or rubber gasket is attached to the door frame to seal in the steam.



This is a close view of the copper water basin set in the floor of the oven. Water can be added to the basin during steaming through a pipe which can be turned on and off from outside the chamber. Note how the tracks are situated so that the cart can roll directly over the basin.



This is a view into the fire box under the oven chamber. It shows the underside of the copper basin and the flue which leads to the chimney in the back corner. The fire is supported on a rack of steel bars to allow good air circulation and the removal of ashes during operation. The owners of this oven said they would convert it soon to burn natural gas instead of wood.



This photo shows a loaded cart being pushed into the chamber for steaming.



Equipment for Stifling Fresh Cocoons

Details of test box, cart and trays for steam stifling oven

Test Box

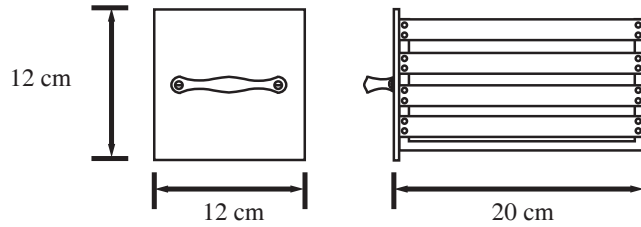

Cart

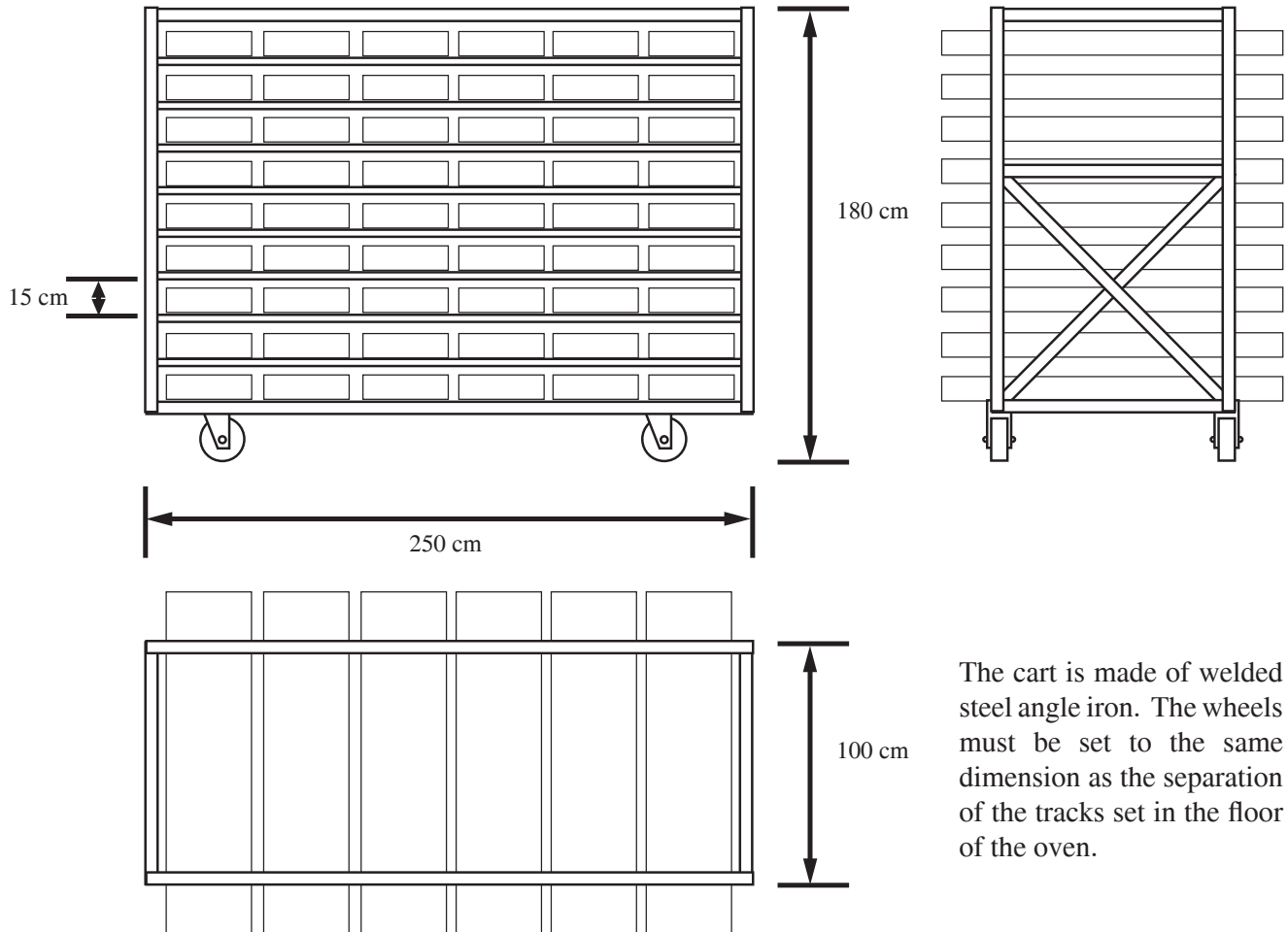

The cart is made of welded steel angle iron. The wheels must be set to the same dimension as the separation of the tracks set in the floor of the oven.

Tray

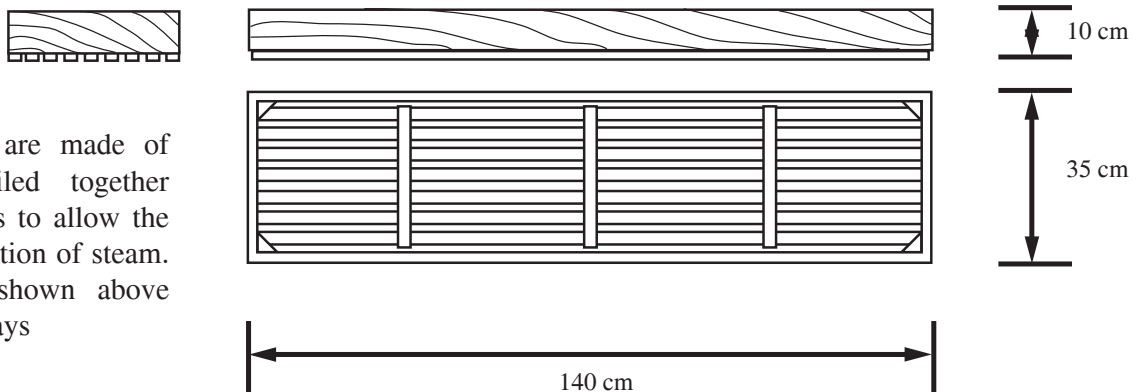

The trays are made of wood, nailed together with spaces to allow the free circulation of steam. The cart shown above holds 54 trays

Equipment for Stifling Fresh Cocoons

Electric stifling and drying oven

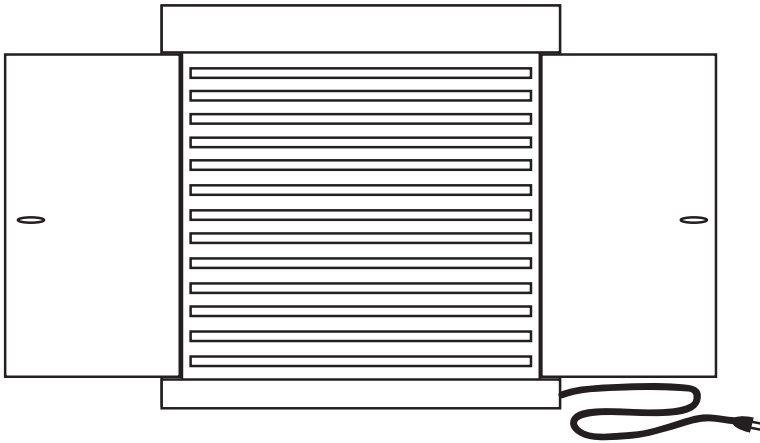

Electric oven systems can both stifle and dry fresh cocoons in one step. They are commonly used in large scale production facilities. They only make sense where electricity is inexpensive and reliable.

Racks for Cocoon Drying and Storage

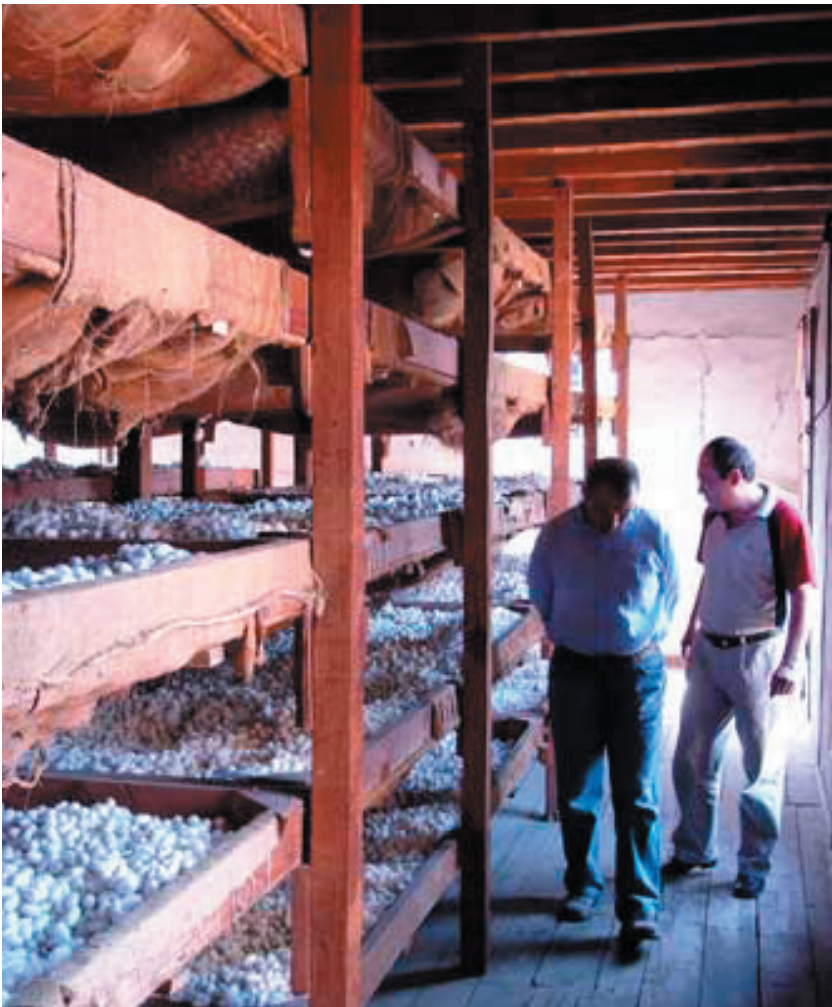

These racks hold approximately 30 kilograms of dried cocoons per shelf. Directly after steam stifling, cocoons are placed on the shelves where they air dry over a period of about two months. This method of storage requires good air circulation and protection against birds, mice and lizards. Screening the windows of the store house and wrapping the lower legs of the racks in aluminum flashing may help prevent infestations. Attach the legs to the ceiling or use cross braces to steady the racks. These racks were said to preserve cocoons for at least two years in temperate climates.

Each rack with five shelves holds about 150 kg.



Building used for cocoon storage above and offices for cocoon producers association below.



Cocoons spread for drying.

Racks for Cocoon Drying and Storage

Wood and burlap racks

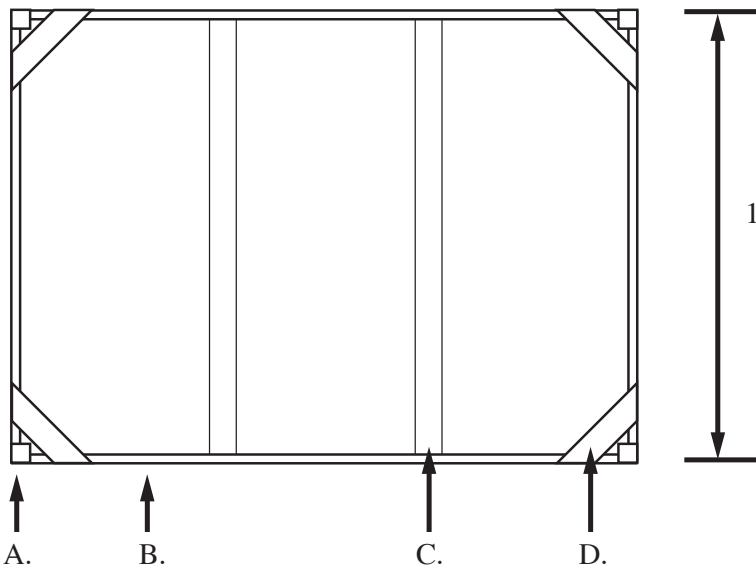
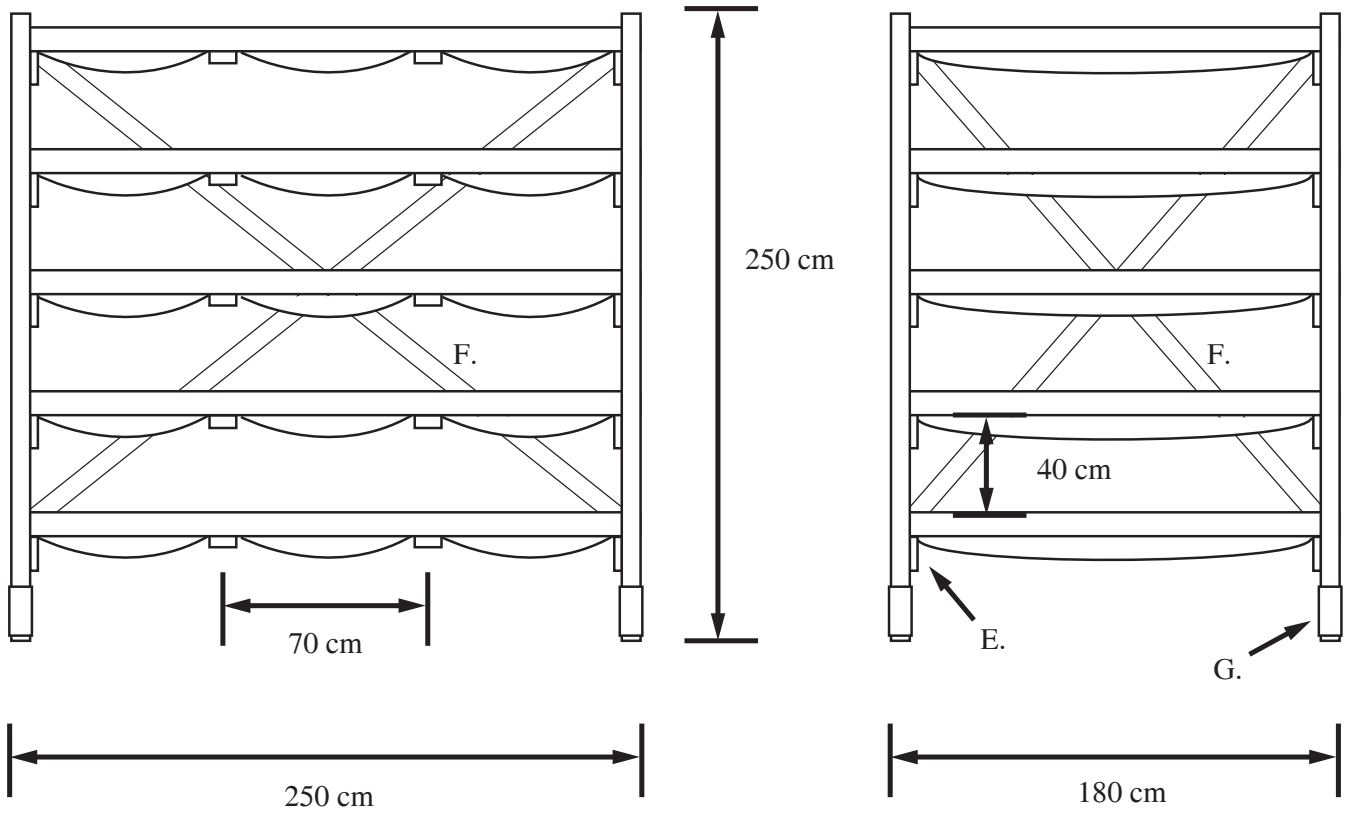

- Cross sectional dimensions of parts:
- A. Uprights: 7.5 x 7.5 cm
 - B. Horizontals: 3.5 x 11 cm
 - C. Middle supports: 3.5 x 5 cm
 - D. Corner braces: 3.5 x 5 cm
 - E. Support blocks: 3.5 x 5 cm
 - F. Optional cross braces: 2 x 5 cm
 - G. Aluminum flashing against mice and lizards

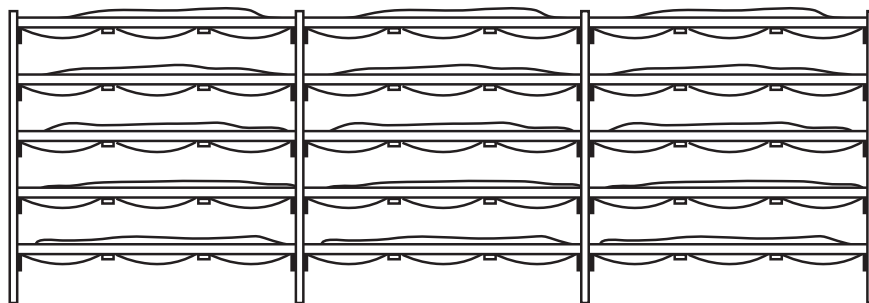

Adjacent racks may share uprights.

Reeling Raw Silk by Machine

Cottage basin type reeling unit



A reeling unit in use in Turkey.

These photos and drawings show a large, fixed, wood-burning reeling unit made mostly of bricks and earth. The door to the fire box is steel and the large water basin is copper. This unit can be operated by either hand crank or electric motor. The motor is attached to a board which pivots to adjust the belt tension and thereby the speed of the reel.

Cocoons are both cooked and reeled from the basin in one operation. The unit can produce four skeins of raw silk at one time and uses a simple croisure and distributor to improve the quality of the raw silk thread and increase efficiency. Some coals from the fire are placed under the distributor to dry the thread before it is wound on the reel. This helps to minimise sticking. This unit was said to require two people and consume about 100 kg of wood to produce



A skein of raw silk reeled using the machine pictured at left.

approximately 8 kg of raw silk per day.

Individual silk strands from 20 - 30 cocoons first pass through a guide hook which gathers them together. There are four guide hooks which are 20 cm above the level of the cocoons at the end of the basin near the reel. The strands then pass from the guides to the croisure. The croisure system is held over the basin by a wooden arm. It uses grooved, wooden beads on a wire to consolidate the strands into a single raw silk thread. The thread then travels to a hook on the distributor arm which is driven by an eccentric wheel which in turn is driven by a belt from the reel axle. The distributor makes flat, untangled skeins of raw silk on the reel. Drawings of the parts mentioned above appear on the following pages.

Reeling Raw Silk by Machine

Cottage basin type reeling unit

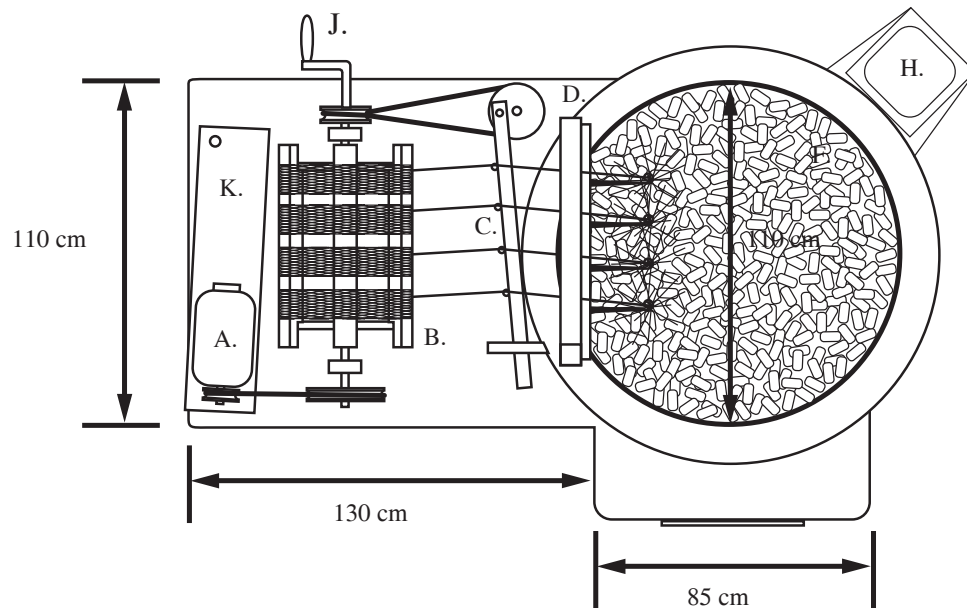
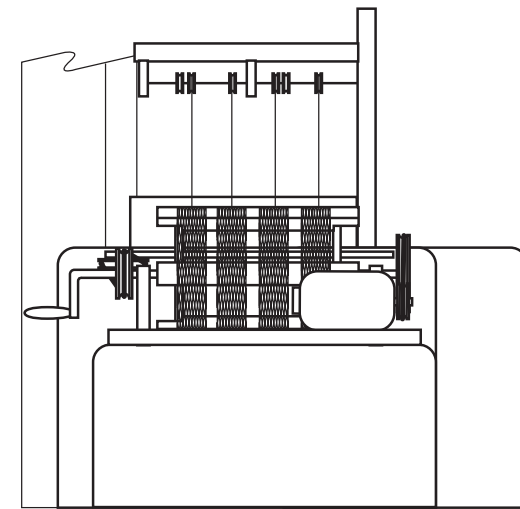
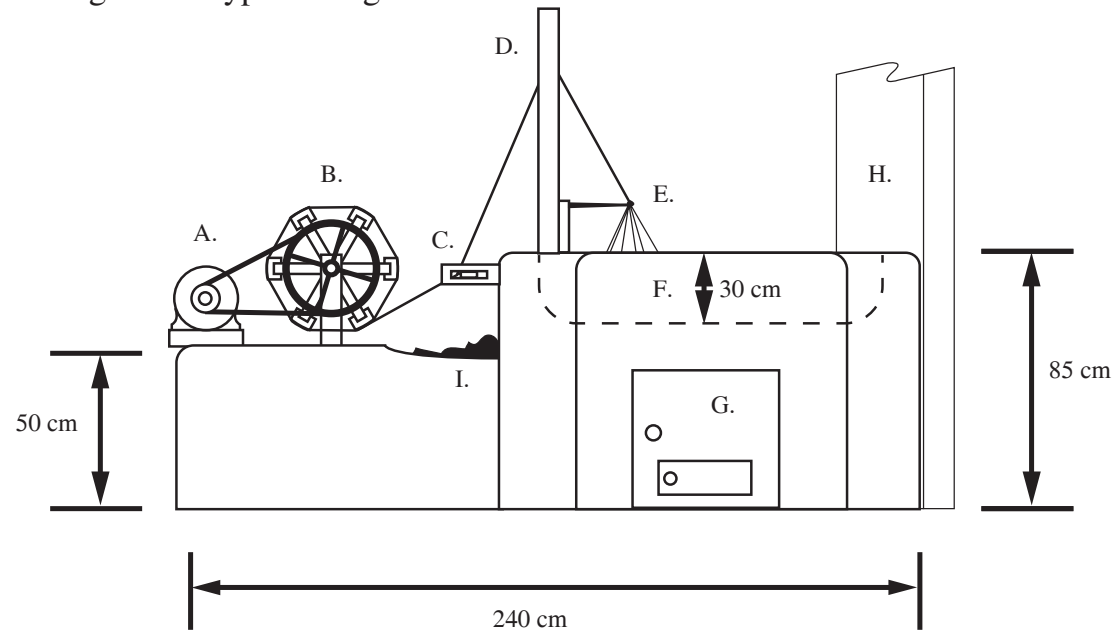

- Parts of the reeling unit:
- A. Electric motor and pulley
 - B. Reel and pulley
 - C. Distributor
 - D. Croisure arm
 - E. Guide hooks
 - F. Basin
 - G. Fire door and vent
 - H. Chimney
 - I. Coal bed
 - J. Hand crank
 - K. Pivoting motor mount

- Some approximate technical specifications:
- Output: 8 kg of raw silk / day
 - Labour: 2 people
 - Fuel consumption: 100 kg of wood / day
 - Reel speed: 120 RPM

Reeling Raw Silk by Machine

Details of the guide hooks and croisure of the cottage basin



Details of the guide hooks from the side and from above. Each hook is 10 - 15 cm long. The hook must be smooth to avoid cutting or shredding the silk fibres.

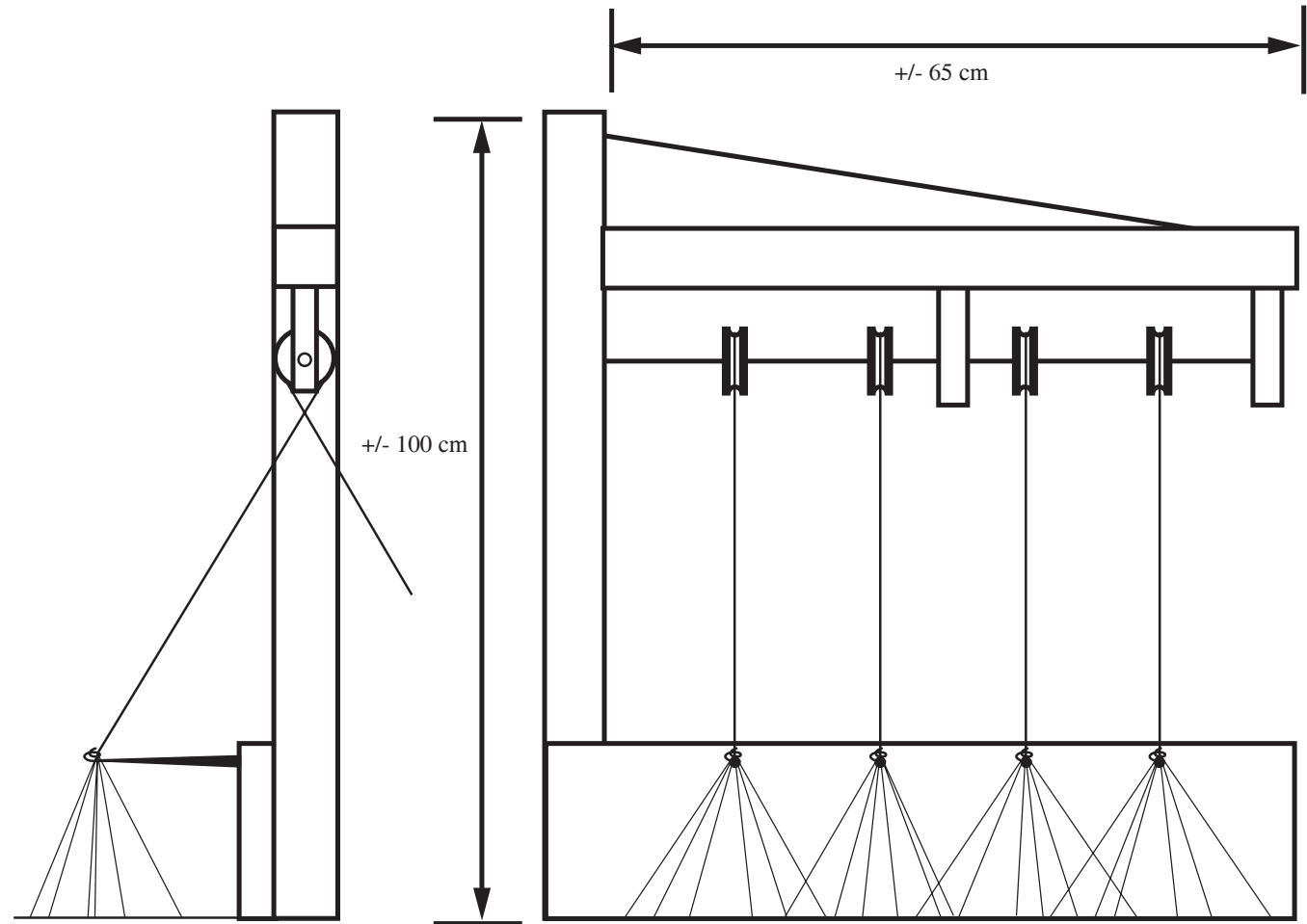

Details of the croisure system. The armature is wood with a cross section of about 6 x 6 cm. The wooden pulley beads spin on a piece of stiff galvanised wire. The horizontal piece of the arm can also be supported by a piece of wire. The guide hooks should be about 20 cm above the level of the cocoons to allow casting on of new fibres.

Reeling Raw Silk by Machine

Details of the distributor and reel of the cottage basin

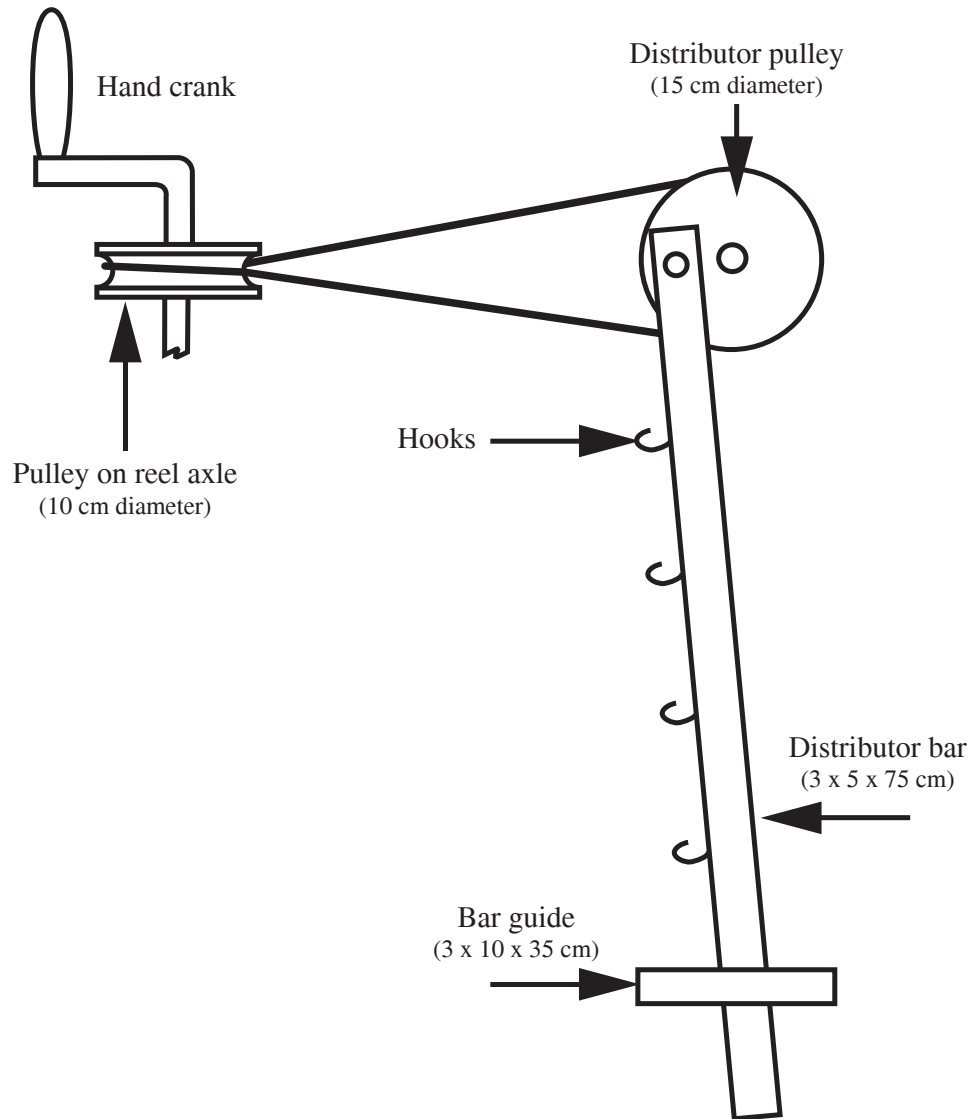

This is a general diagram of the distributor assembly. The end of the bar which is attached eccentrically to the distributor pulley moves in a circle whenever the reel is turning. The bar guide is anchored into the masonry of the basin.

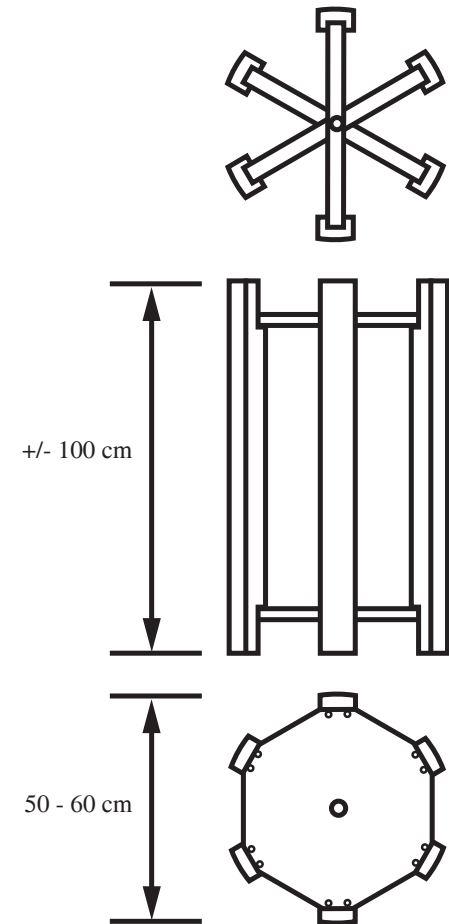

Drawing showing two ways to make a reel. On top is the solid wood, wagon wheel type. At the bottom is the plywood type which is easier to make. The reel can be smaller at the hand crank end to allow the skeins to slide off or have a mechanism to loosen one cross piece. The cross pieces must be smooth to prevent snagging.

Reeling Raw Silk by Machine

Details of the mechanisms seen from above

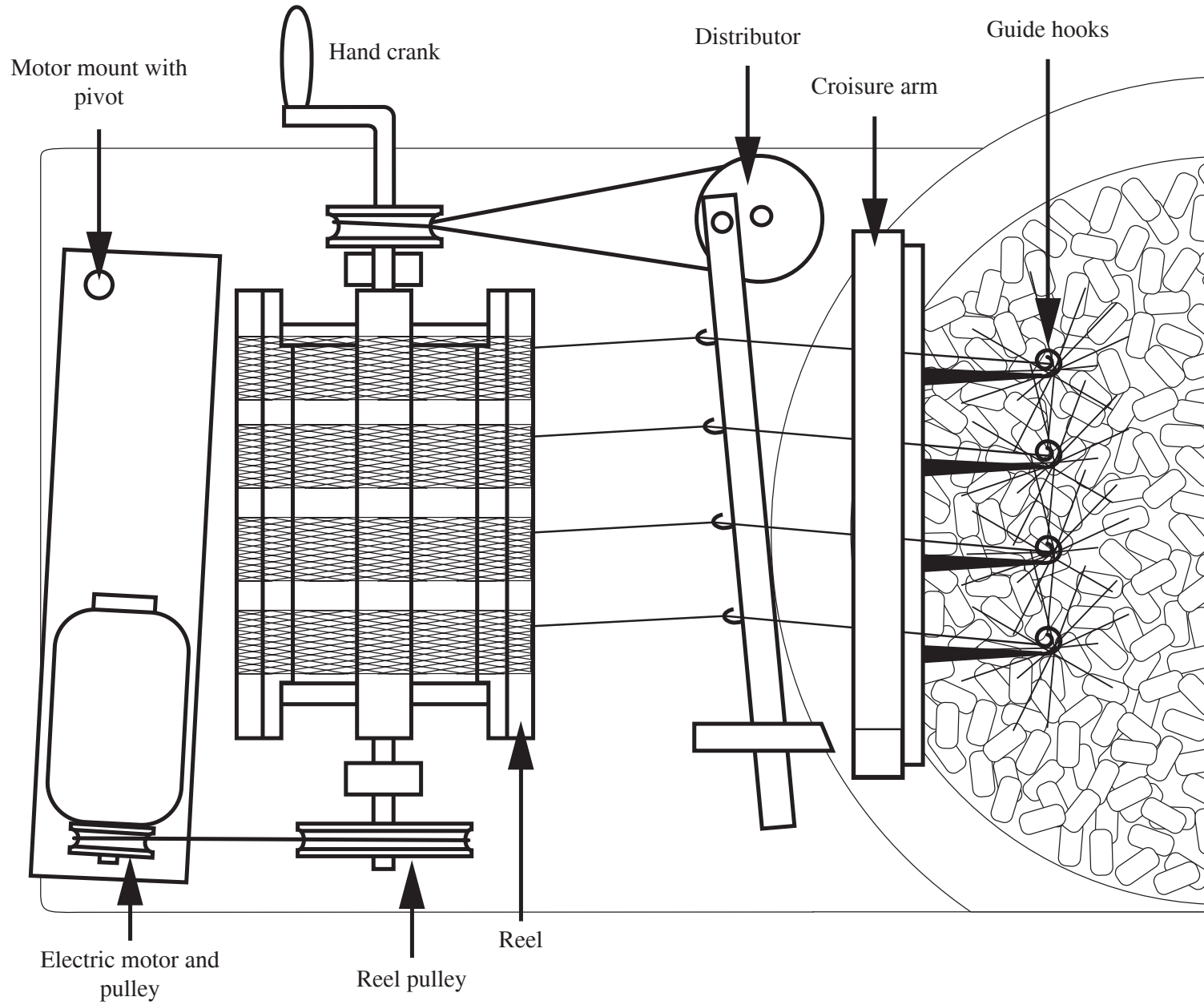

Reeling Raw Silk by Machine

Wood frame type reeling unit

These drawings show a small, moveable alternative to the cottage basin reeling unit shown above. This tool is made mostly of wood and can be transported or stored when not in use. These drawings are meant only as a suggestion. A unit like the one pictured here can be powered by hand crank or treadle or fixed with a small electric motor.

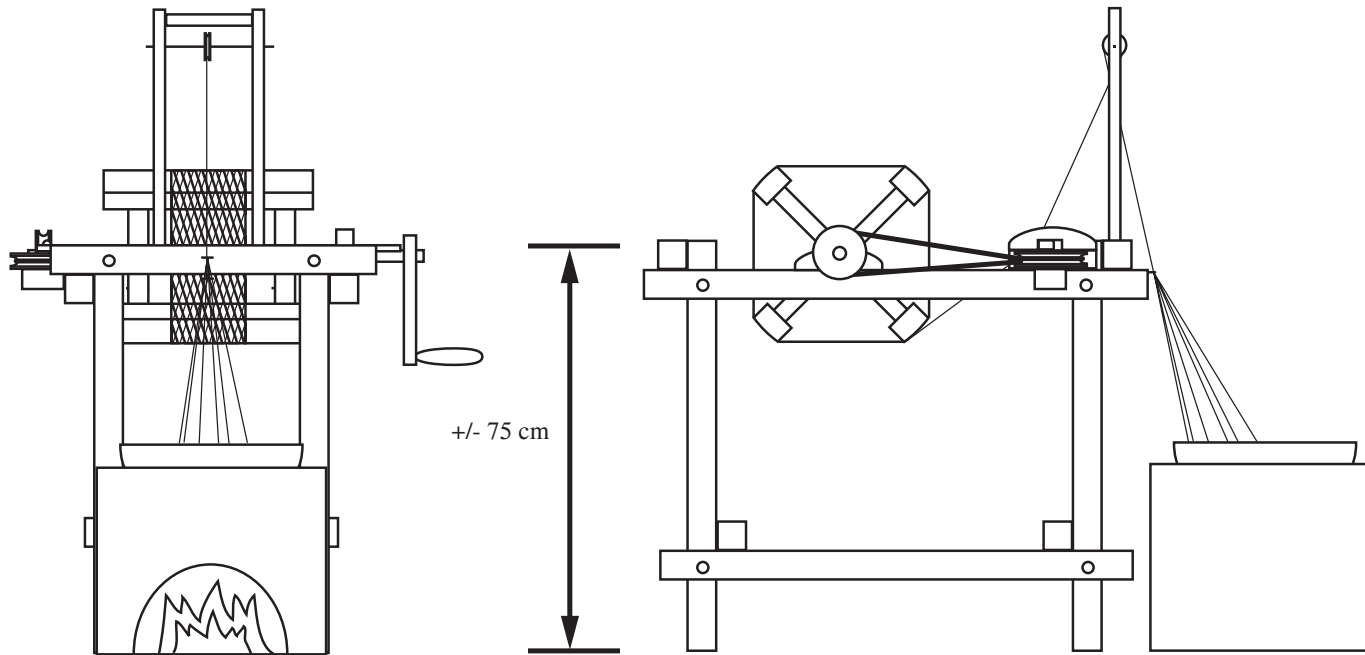
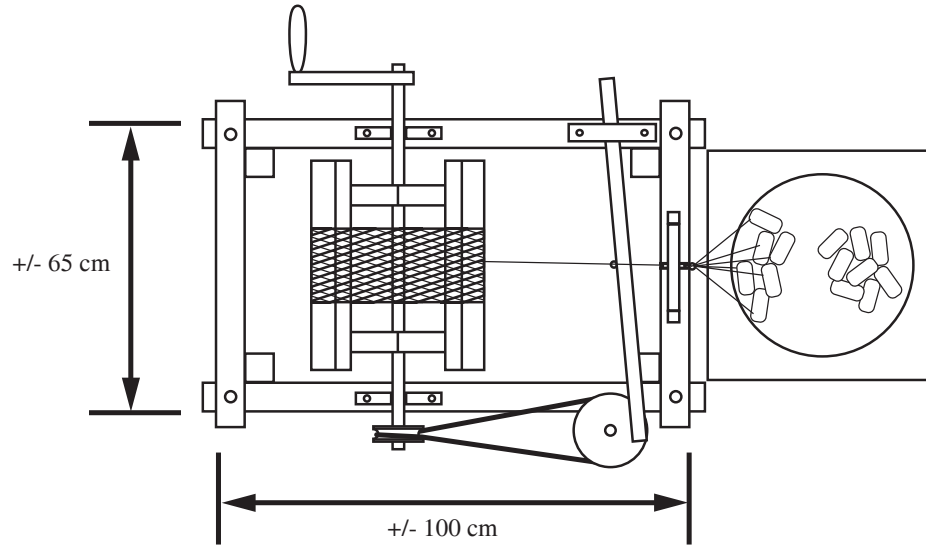

Producing Raw Silk by Hand

Hand Stripping



Hand stripping raw silk. The woman on the right is producing the thread. The woman on the left is winding the thread onto the wooden spindle.

The simplest way to produce raw silk from cocoons is by hand stripping. The individual fibres from several cocoons are pinched between the fingers of one hand while the other hand pulls the consolidated thread through. In the photograph above, the woman at right is producing the raw silk thread and piling it on the platter seen behind the pot of cocoons. The platter is covered with dry wheat berries which she said prevented the thread from sticking to itself. The woman at left is winding or reeling the raw silk onto the spindle. The process is surprisingly fast for its simplicity and may be economical for hand stitchers or embroiderers who need relatively small amounts of silk. The cocoons can be cooked over charcoal or gas.

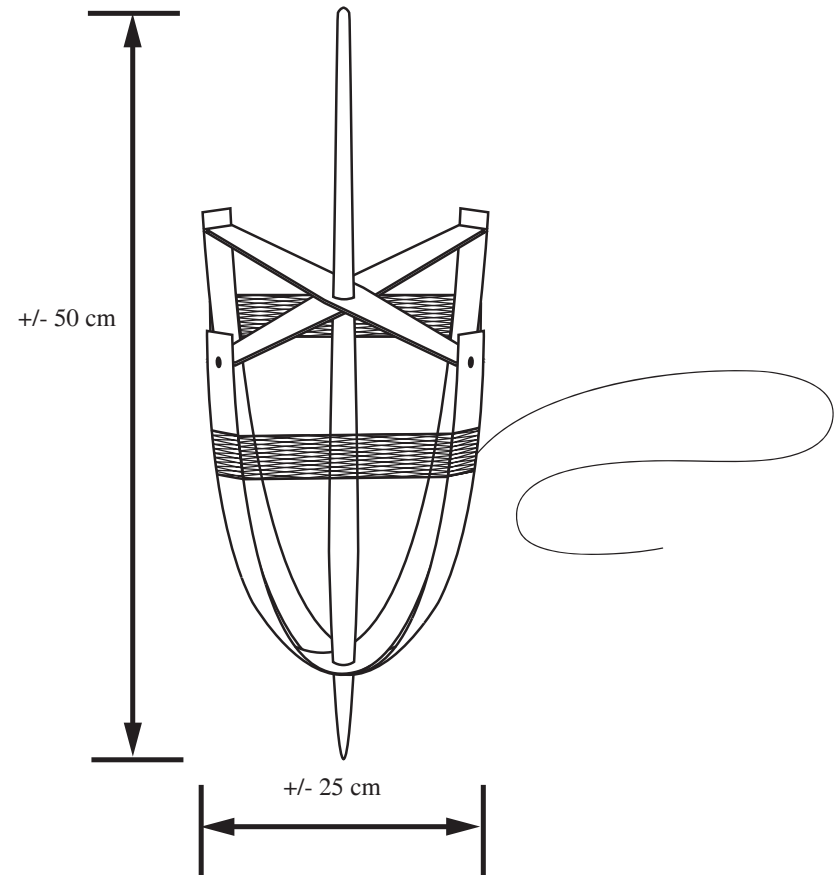

Wooden spindle shown in the photograph at left.

Producing Raw Silk by Hand

Hand Stripping Basin with Croisure

This is a type of small reeling basin traditionally used in South East Asia. The one pictured below is from Thailand. It has a small reel-like croisure supported above the basin by a metal frame. The fibres from the cocoons pass through an eyelet attached to the frame and then are wound once or twice around the reel. The raw silk thread is stripped by hand in a way similar to that described above. It is piled on a tray or cloth to be wound into a skein. The basin should be made of copper or other non-rusting metal. Steel or iron will stain the cocoons with rust.

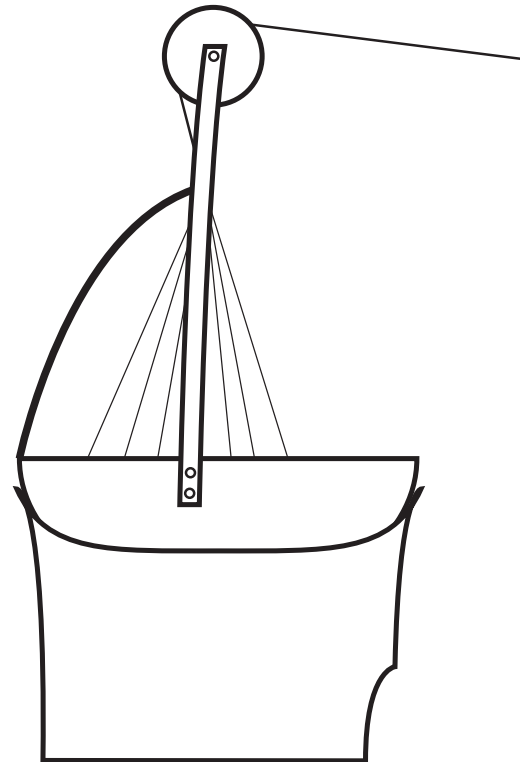
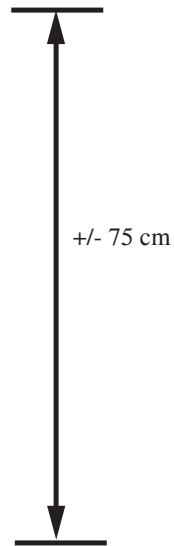
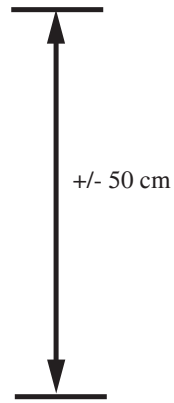
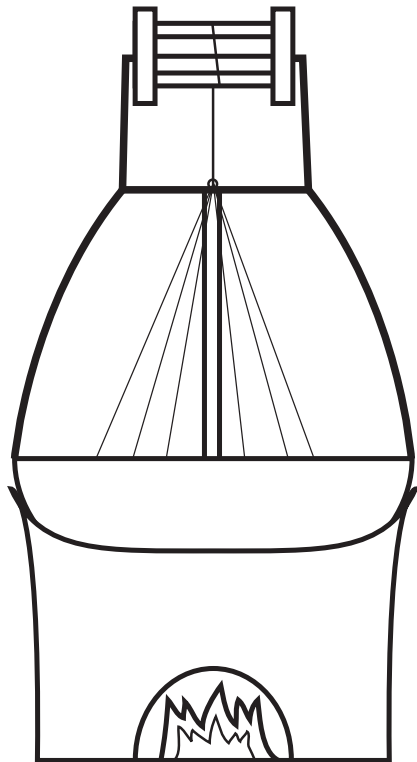

Equipment for Twisting, Doubling, Spinning and Winding



Using a wooden hand wheel to wind yarn onto a bobbin for weaving.

These pages show simple equipment used for twisting, doubling, spinning and winding of silk and other fibres. The drawings show a number of designs which can be easily made by a carpenter or wood worker.

Twisting

Most silk yarns are twisted to some degree. Twisting increases the strength of the yarn and changes the characteristics of its lustre.

Doubling

Yarn is doubled to to make it thicker and to blend fibres or colors.

Spinning

Degummed floss and other remainders from the reeling process can be spun with a hand wheel into either all silk or silk-blended yarns.

Winding

Skeins are wound for dyeing, for storage or for sale. Bobbins are wound for weaving with shuttles.



Skein winder with electric motor. This tool is only for winding skeins.

Equipment for Twisting, Doubling, Spinning and Winding

Wood and wire wheels



Wooden hand wheel.

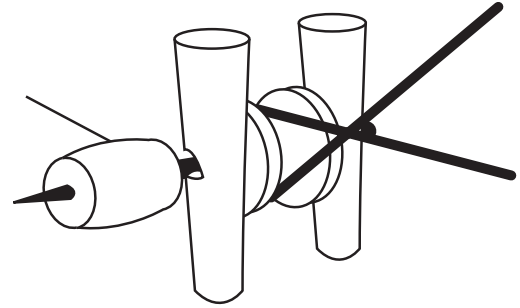

Detail of spindle, spindle wheel and drive band. Cloth or oiled leather is used as a bearing.

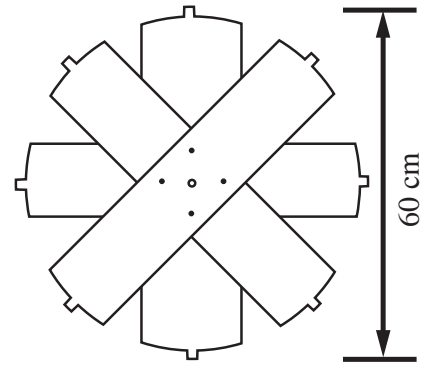
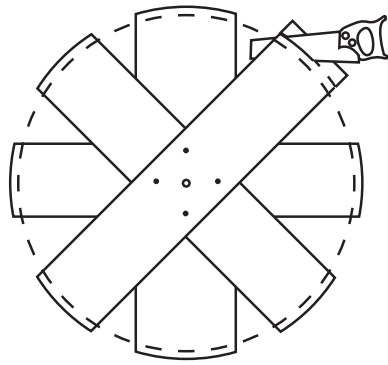
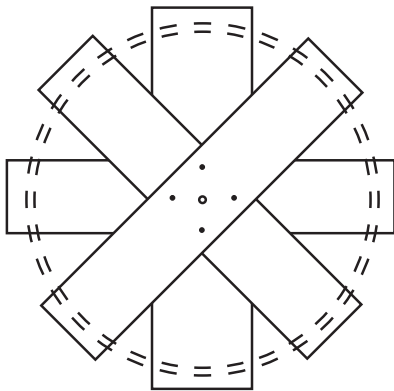

This shows the procedure for making a simple wooden drive wheel for the tool pictured below. Thin boards are nailed together and then cut into a circle. Some small tabs are left or nails are driven in the ends of the boards to hold the wire or lacing which supports the drive band.

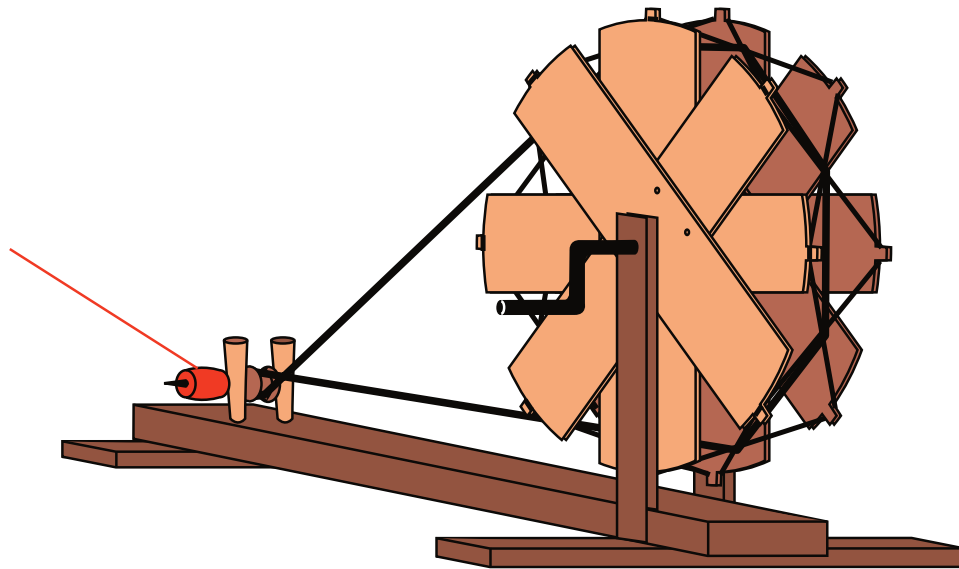

Drawing of a wooden hand wheel seen from the operators side showing the hand crank.

Equipment for Twisting, Doubling, Spinning and Winding

Two types of spinning wheels made with bicycle wheels

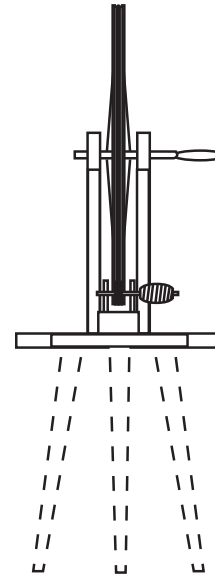
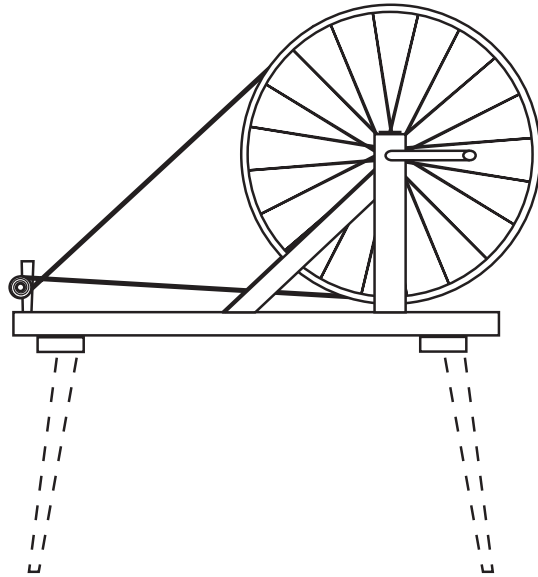
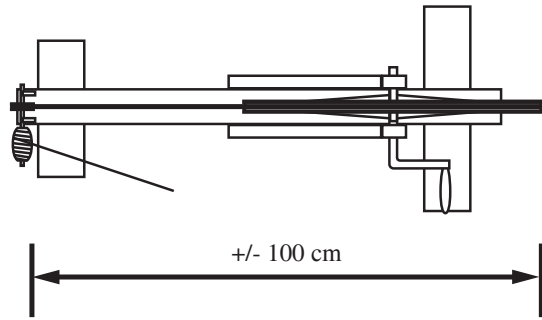

This wheel can be made with or without legs.

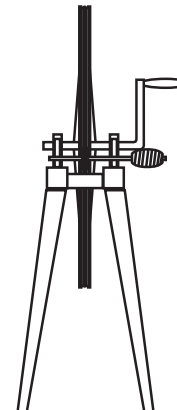
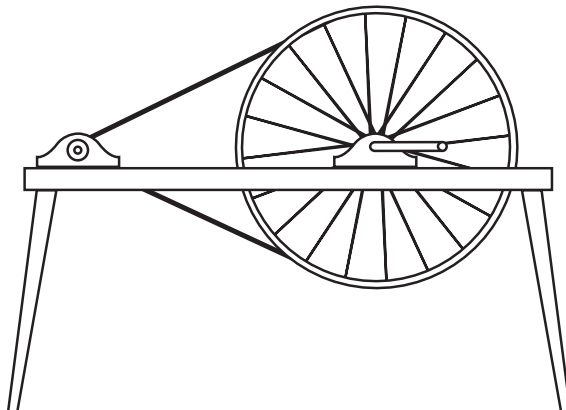

This wheel is made with legs.

Equipment for Twisting, Doubling, Spinning and Winding

Charka type wheel used for twisting, doubling, spinning and winding.

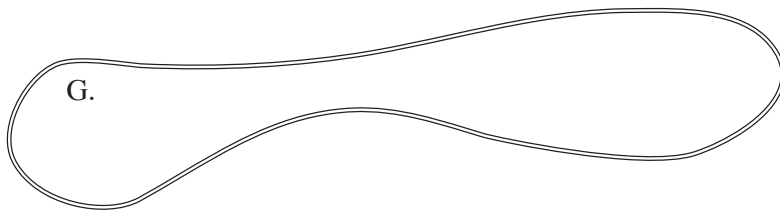
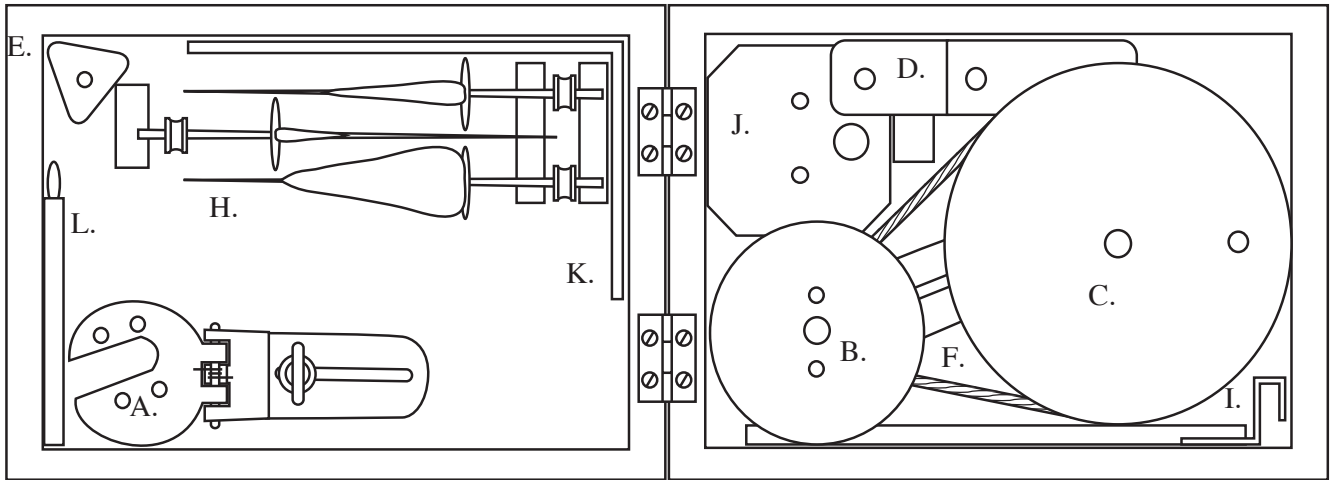

Parts of a Charka:

- A. Spindle holder and bearings
- B. Accelerator wheel and tensioner
- C. Drive wheel
- D. Crank handle
- E. Crank handle knob
- F. First drive band
- G. Second drive band
- H. Spindles
- I. Stabilising bar
- J. Skein winder hub
- K. Skein winder arms
- L. Lead eye for winding skeins

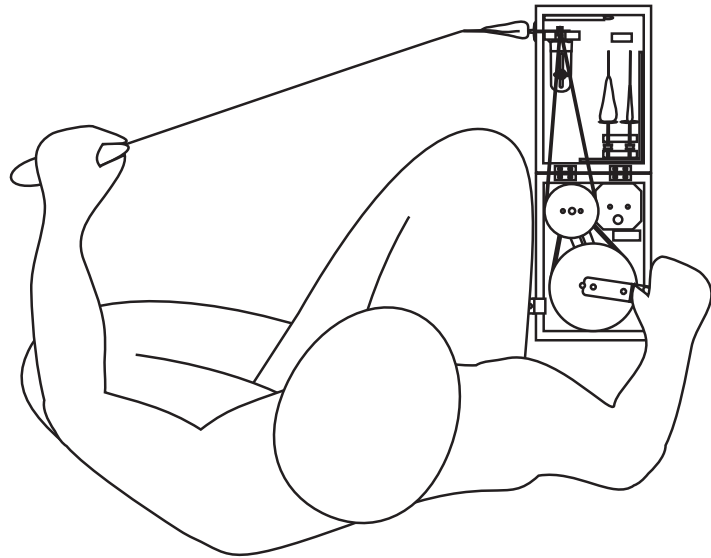

Sitting position while using the charka

This is a small, portable, multifunction tool commonly used in India for hand-spinning. It could also be used for twisting reeled silk, doubling yarns and for spinning degummed floss and other waste fibre into pure silk or silk-blended yarns. It can also wind bobbins for weaving and wind skeins of finished yarns. Charkas, also spelled charkhas, are made in large numbers.

Equipment for Twisting, Doubling, Spinning and Winding

Charkas in two modes of operation.

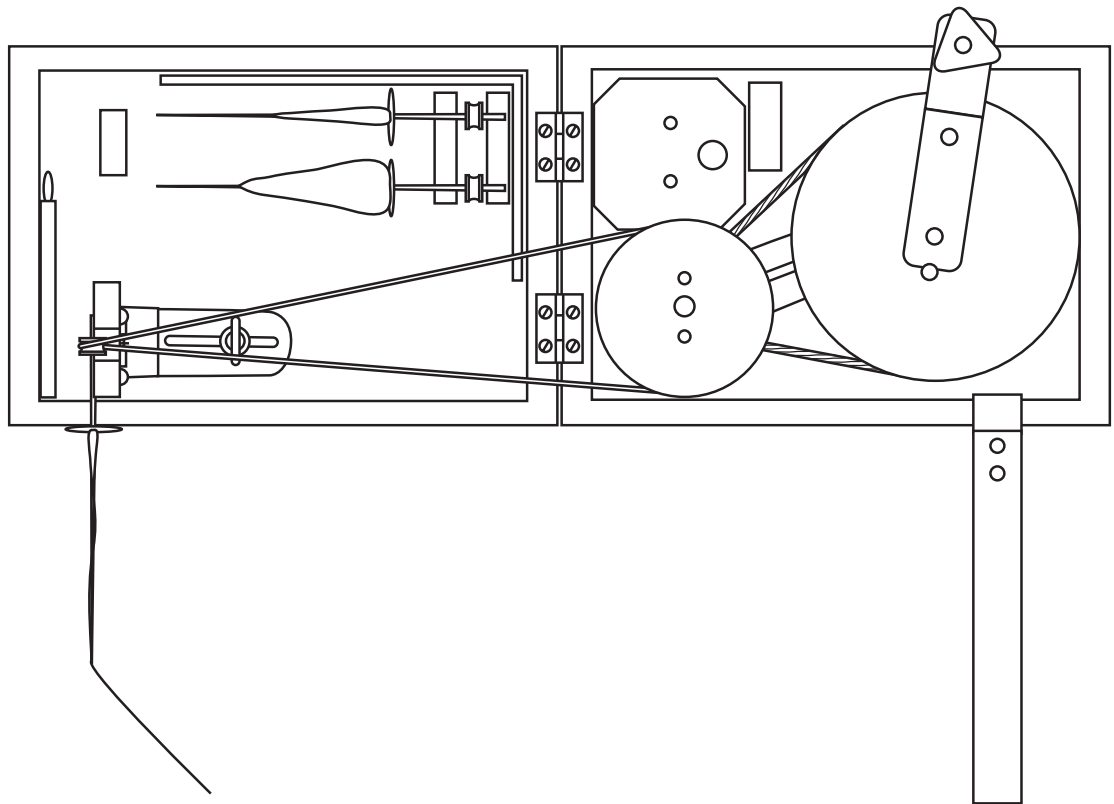

Charka set up for twisting, doubling, spinning and for winding bobbins.

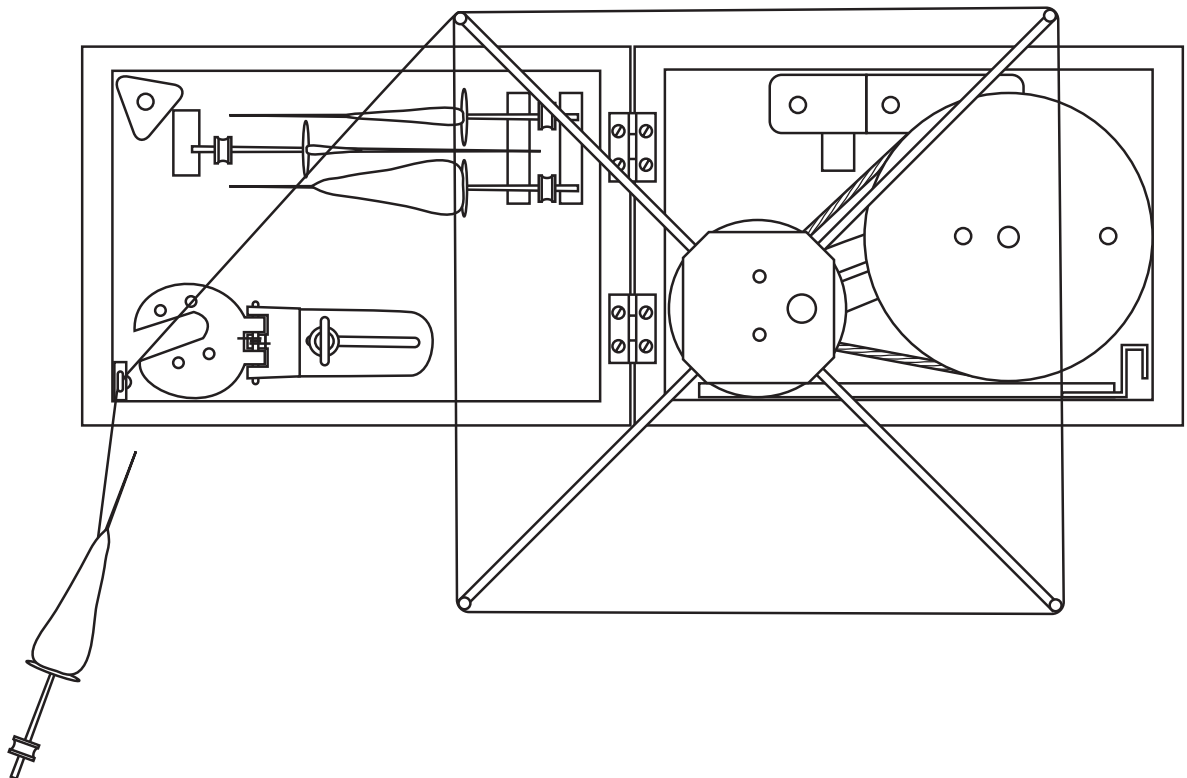

Charka set up for winding skeins.

Equipment for Carpet Weaving

Wooden carpet loom

These photos and drawings show vertical, wooden looms commonly used in Turkey for weaving silk carpets. They can be made by a carpenter or woodworker. The looms use steel tensioning bolts with nuts and washers which are adjusted with a wrench to tighten and loosen the warp threads. The bottom bar of the frame moves up and down in a 30 cm slot cut in each leg of the frame. The frame is held together with wooden pegs and can be disassembled for transportation or storage if necessary. The given dimensions come from a loom which is used to make carpets with a maximum size of approximately 100 cm x 200 cm. In the photo at right, the pattern is seen resting on the heddle and skeins of colored silk yarn are seen on the upper bar of the loom.



Beginning a new carpet.

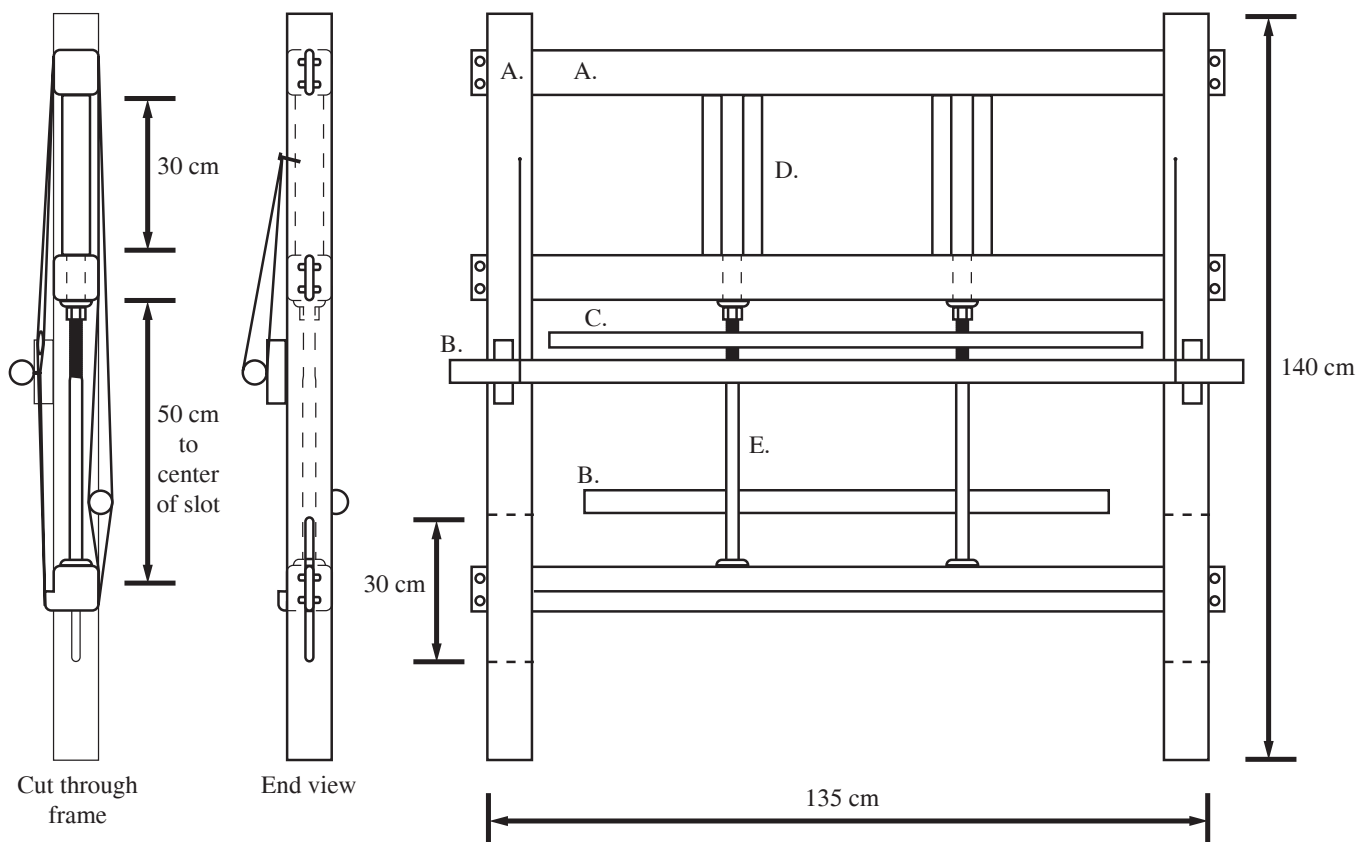

Cross sectional dimensions of some parts:

A. Frame: 8.5 x 8.5 cm

B. Heddle rod: 4.5 cm diameter round

C. Shed rod: 1.5 x 4 cm ellipse

D. Tie bars: 2.5 x 6.5 cm

E. Steel tensioning bolts: 2 x 70 cm with at least 20 cm threaded

Metal carpet loom

This metal loom is a simplified version of the wooden looms shown above. The side frames are made of 4 x 4 cm square steel tube and the upper and lower bars are steel pipes about 20 cm in diameter. The heddle bar is supported by two metal hangers shown in the drawing below. A metalworker with welding equipment can fabricate this loom.

The metal frame is more rigid than the wooden one. This allows the tension adjustment bolts to be placed at the ends of the lower bar making tension adjustments faster and easier. The upper bar is also moveable which allows a larger size-range of carpets to be made on the same loom. The entire loom is bolted to the floor. This loom is not as easy to disassemble and transport as the wooden one and is likely to be more expensive to build in most communities.



An idle metal loom.

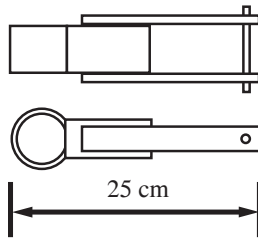

Detail of heddle hanger

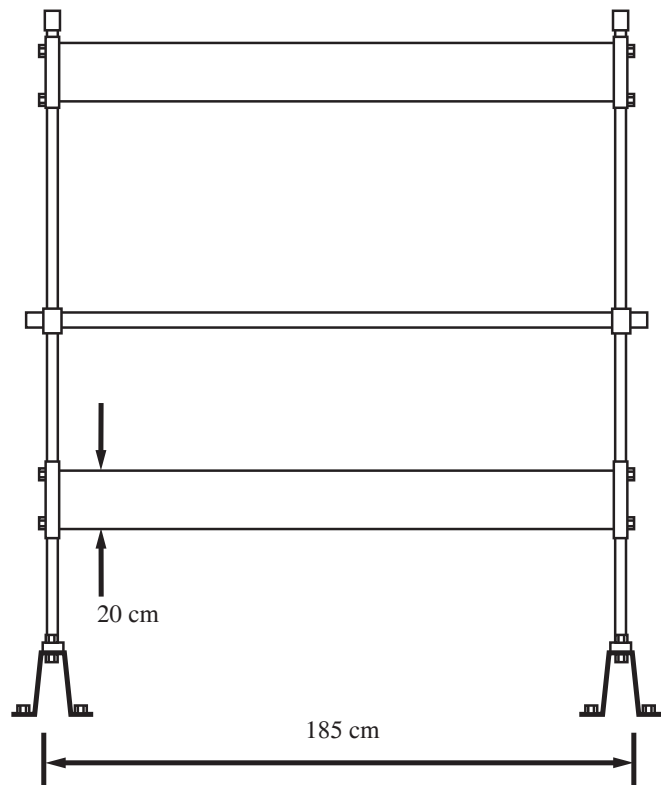
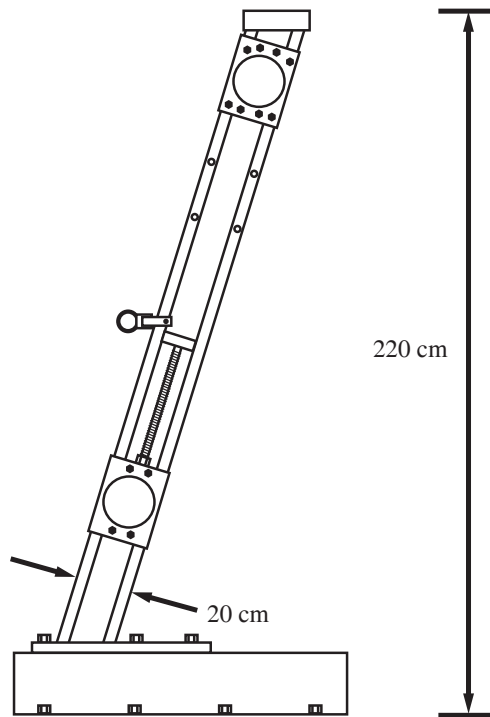

Equipment for Carpet Weaving

Loom prepared for weaving

A wooden carpet loom shown during weaving. The warp threads are strung and the heddle and shed rods are seen on the front side of the loom. Braces hold the loom at an angle to allow comfortable working. The weaver sits on a bench in front of the loom. Every other warp thread is laced to the heddle to allow the separation of the warp for the weft thread to be passed through. The shed is inserted into the warp so that those warp strings which are laced to the heddle go under the shed rod and the strings not laced to the heddle go over. Twisting the shed rod separates the warp in the sense opposite to that of lifting the heddle.

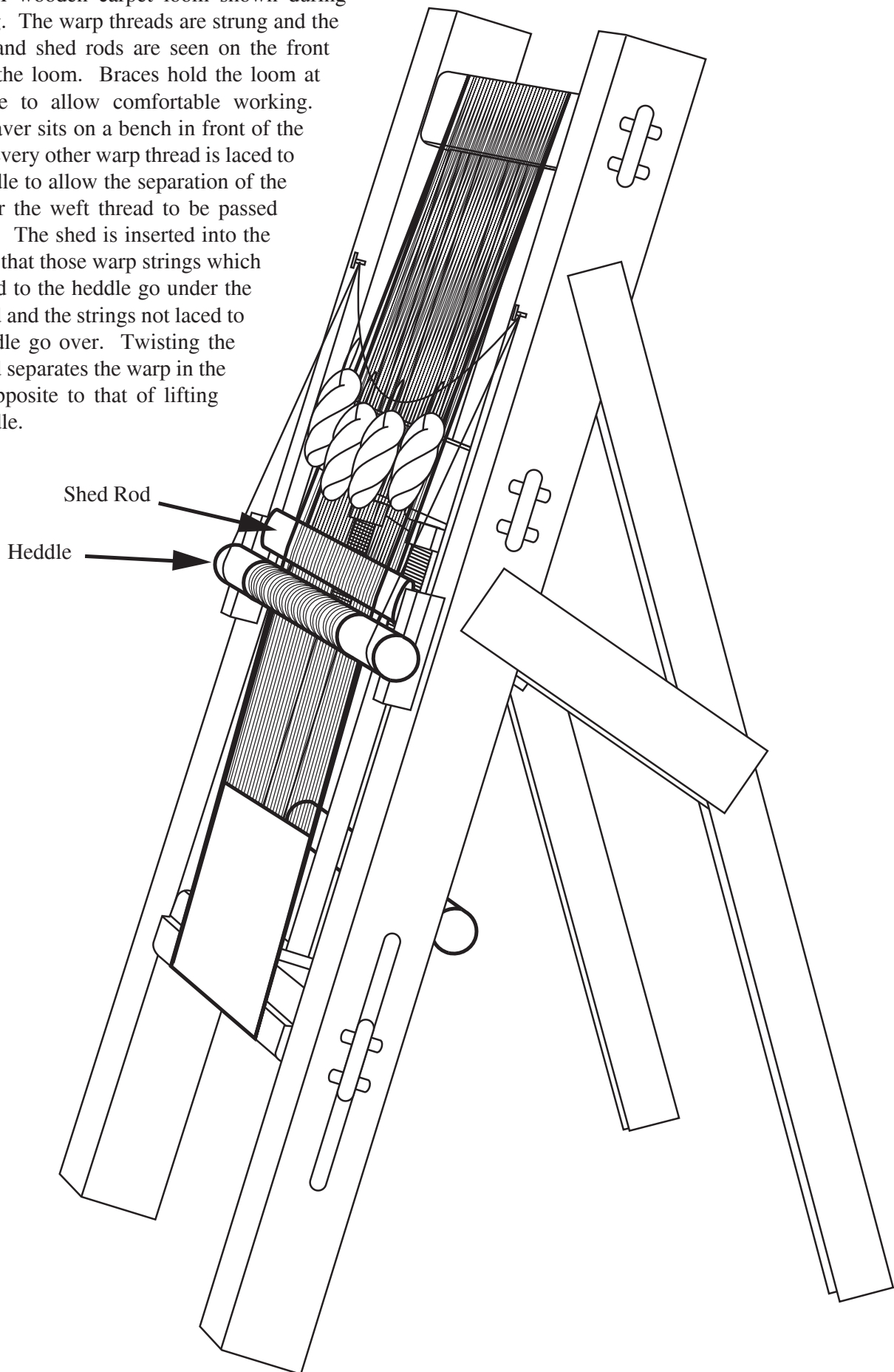

Equipment for Carpet Weaving

Hand Tools for Carpet Weaving

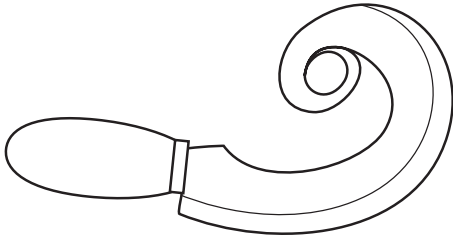
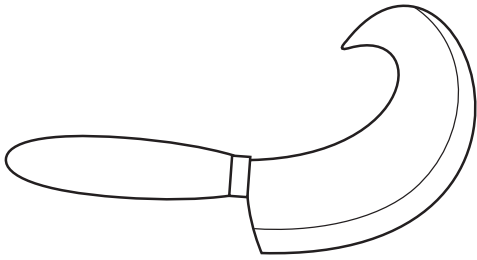
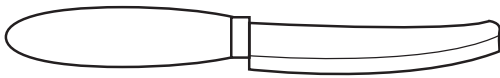

Knives

A small knife is used to cut the silk thread each time a knot is tied to the warp. A simple kitchen knife like the one shown at top left with a blade of approximately 5 cm is sufficient. Many regions have traditional designs such as the middle knife from Pakistan and the lower knife from India.

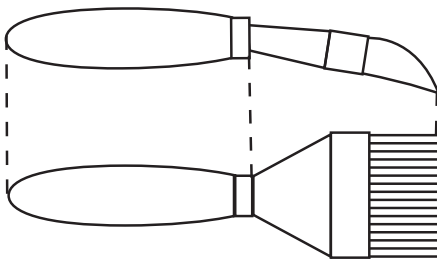
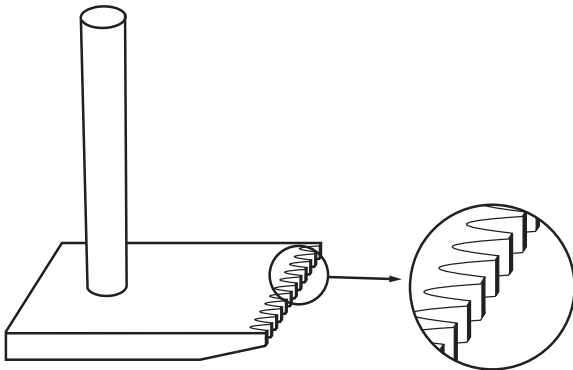

Weft beater combs

The weft beater comb is used after the weft threads have been woven in to secure the row of knots. They must be heavy and the teeth of the comb must be smooth so they do not cut the weft. The top comb is made from a piece of steel about 1 x 8 x 10 cm with a steel handle about 15 cm long. The comb has approximately 20 teeth ground into the 8 cm edge. A more traditional comb is shown below. The teeth are cut, stacked and then brazed together. It has a wooden handle which is often decorated.

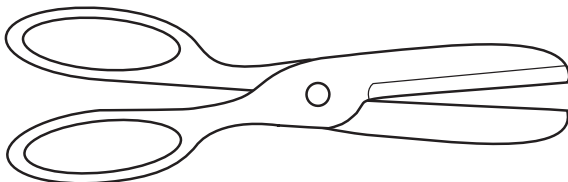

Shears

Shears are used to trim the whole line of knotted threads to the length of the pile.

Handlooms for Weaving Cloth

Backstrap loom

The backstrap loom is one of the simplest and most common handlooms in the world especially in the Americas. It is named for the swing-like seat which the weaver uses to put tension on the warp with his or her body weight. They have all of the basics elements of larger looms but are easily stored and transported. Not shown in the drawing at right is the shuttle which is used to pass the weft through the warp. Shuttles can come in many forms depending on the type of weaving being done. These looms can be used to weave cloth of varying complexity from coarsely plainwoven cloth to richly detailed, unique designs on a very fine scale. The horizontal wooden elements shown in the drawing at right can be from 20 to almost 100 cm long. Cloth woven on a backstrap loom is limited in width. Long, narrow pieces are often cut and joined edge to edge to make them larger.

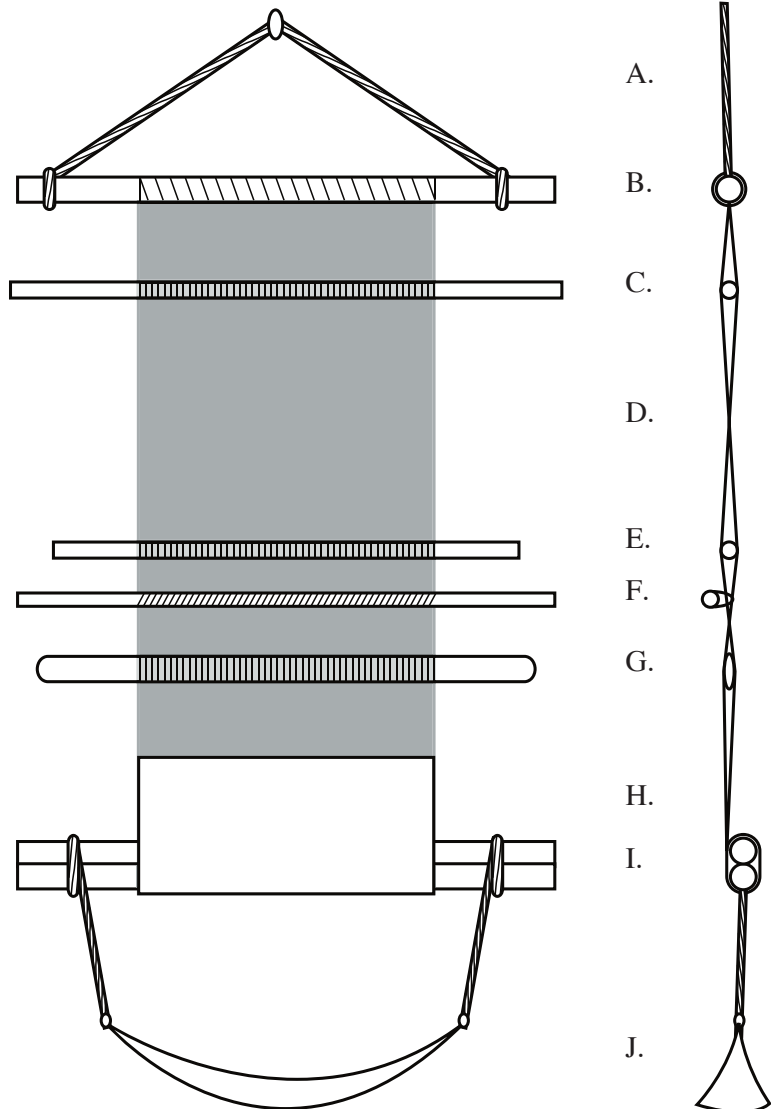

Elements of a generalized backstrap loom:

- A. Tether cord which is tied to a fixed object
- B. Upper bar to which the warp is laced
- C. Lease rod which helps to keep the warp organized
- D. Warp
- E. Shed rod
- F. Heddle rod
- G. Batten for beating the new weft thread against the previous one
- H. Woven cloth
- I. Lower bars around which the woven cloth is rolled
- J. Backstrap

Handlooms for Weaving Cloth

Treadle loom

Though large, fixed looms can be very complex machines, they have the same basic elements seen in carpet and backstrap looms. The details of their design are varied, often strongly traditional and regionalized.

Essential parts of a simple treadle loom:

- A. Bench
- B. Front bar where the woven cloth is rolled
- C. Arm which supports the mechanisms
- D. Reed
- E. Heddles
- F. Lease rod
- G. Warp
- H. Back bar
- I. Foot pedals
- J. Frame

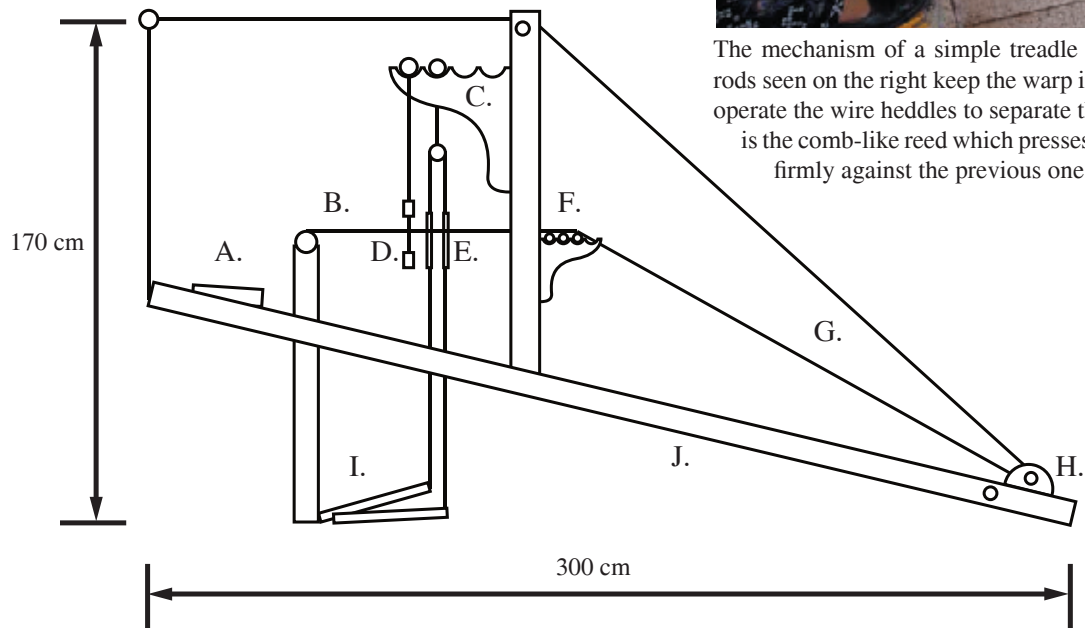

The mechanism of a simple treadle loom. The wooden rods seen on the right keep the warp in order. Foot pedals operate the wire heddles to separate the warp. On the left is the comb-like reed which presses the new weft thread firmly against the previous one.

